

GT2 50/35/45L left

Technical data
Version 2019/08

General technical information	
Recommended wood load	10 kg
Maximum cross-section of the supply air connection	180 cm ²
Combustion air connection	1 × Ø 150 mm
Free glass area	2 555 cm ²

Load of wood	Air flow		Pressure drop
3 kg	28,2 m ³ /h	0,008 m ³ /h	0,8 Pa
4 kg	37,6 m ³ /h	0,010 m ³ /h	1,2 Pa
5 kg	47,0 m ³ /h	0,013 m ³ /s	1,8 Pa
6 kg	56,3 m ³ /h	0,016 m ³ /s	2,6 Pa
7 kg	65,7 m ³ /h	0,018 m ³ /s	3,6 Pa
8 kg	75,1 m ³ /h	0,021 m ³ /s	4,7 Pa
9 kg	84,5 m ³ /h	0,023 m ³ /s	6,0 Pa
10 kg	93,9 m ³ /h	0,026 m ³ /s	7,4 Pa
11 kg	103,3 m ³ /h	0,029 m ³ /s	9,0 Pa
12 kg	112,7 m ³ /h	0,031 m ³ /s	10,8 Pa
15 kg	140,9 m ³ /h	0,039 m ³ /s	17,1 Pa
20 kg	187,8 m ³ /h	0,052 m ³ /s	30,8 Pa

GT2 50/35/45L left

Technical data
Version 2019/08

air connection

M 1:10

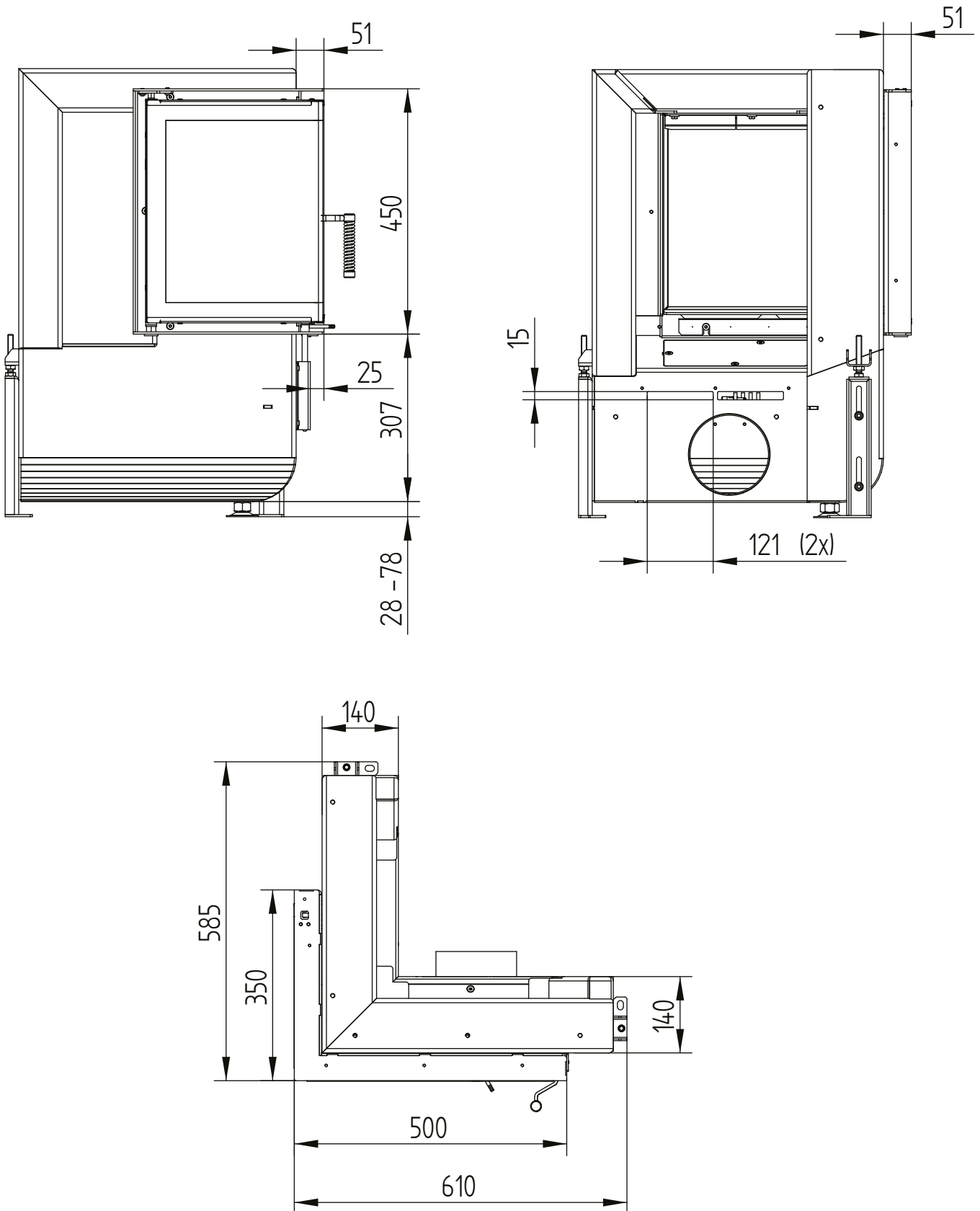

GT2 50/35/45L left

Technical data
Version 2019/08

with base

M 1:10

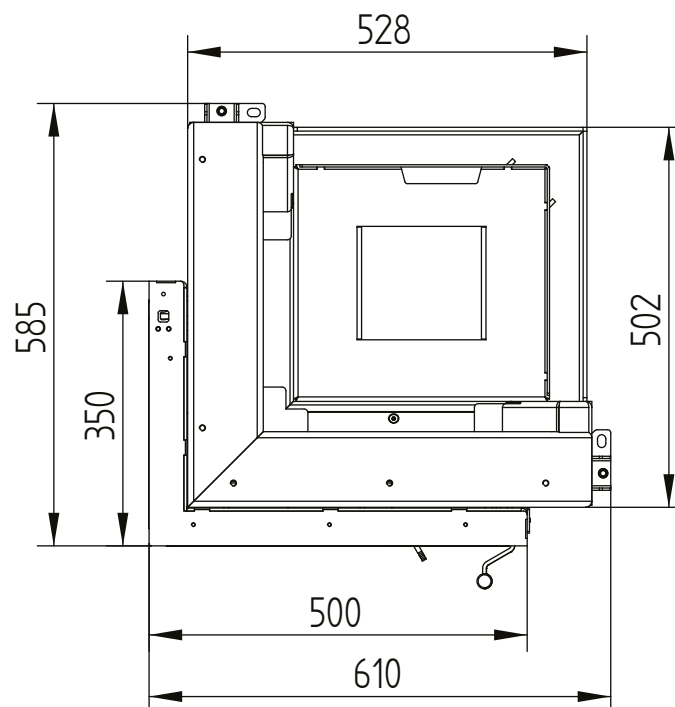
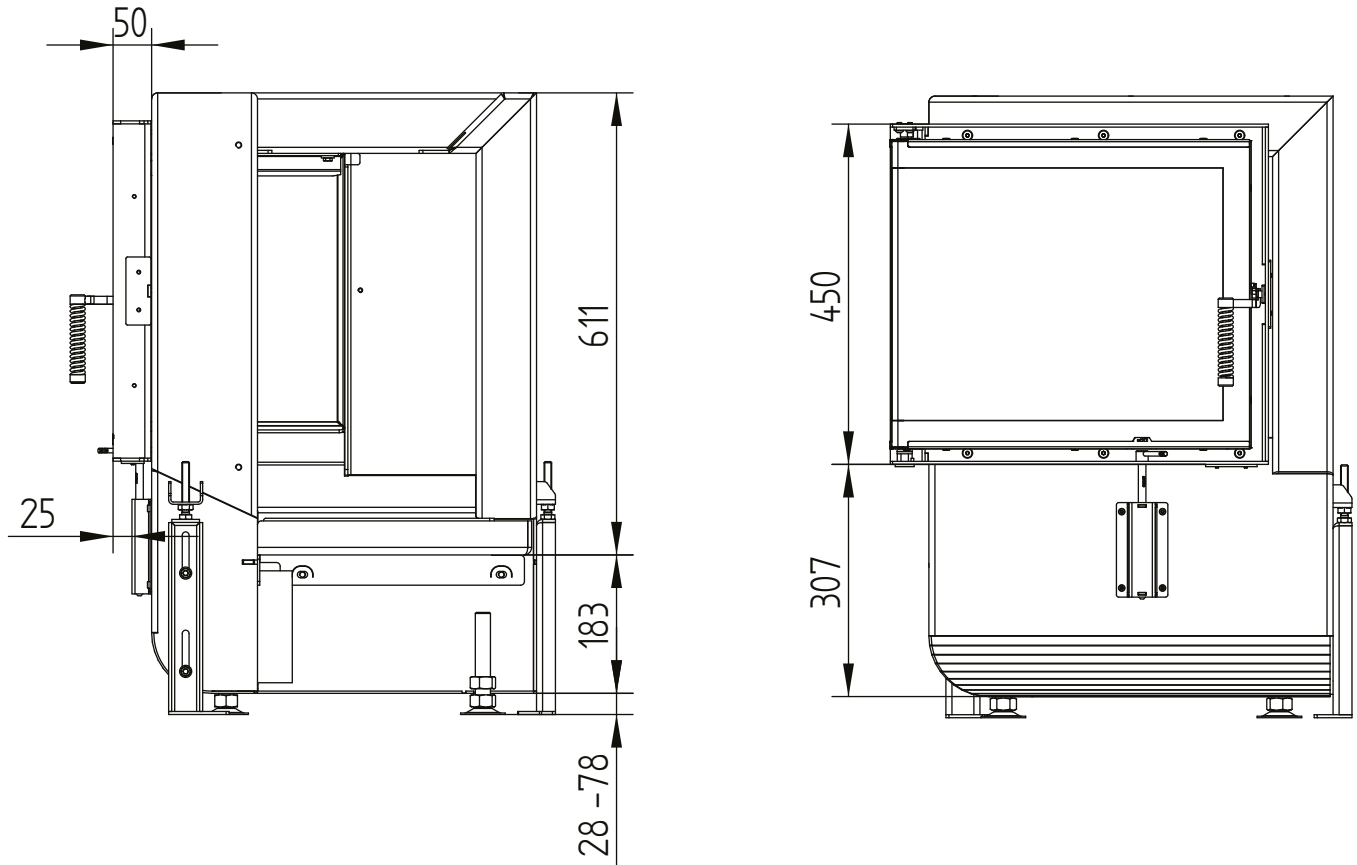

GT2 50/35/45L left

Technical data
Version 2019/08

cover frame 50/35/45L left 6sides 1 x 90° 60 mm

M 1:10

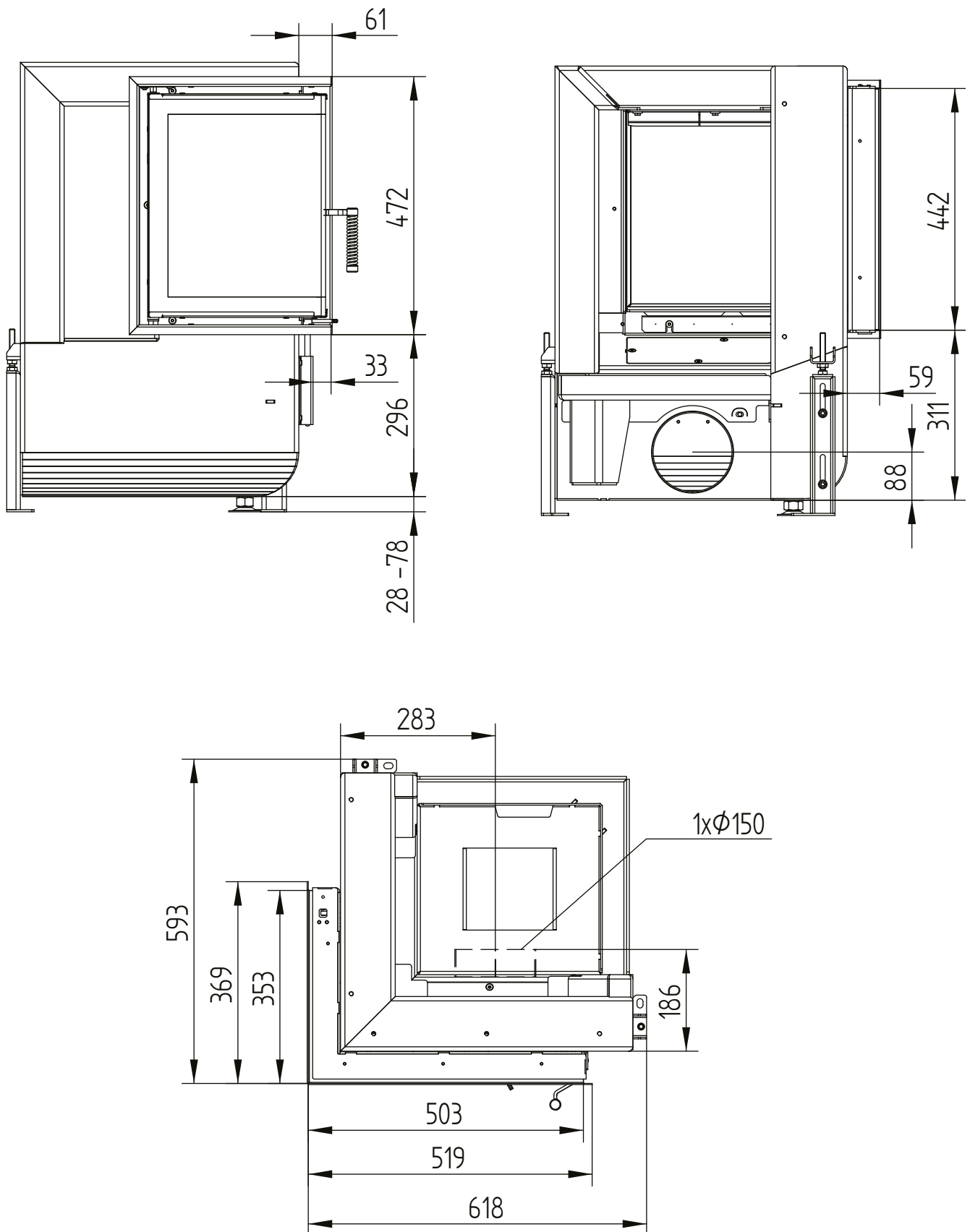

GT2 50/35/45L left

Technical data
Version 2019/08

build-on frame 50/35/45L left 6sides 80 mm / feet

M 1:10

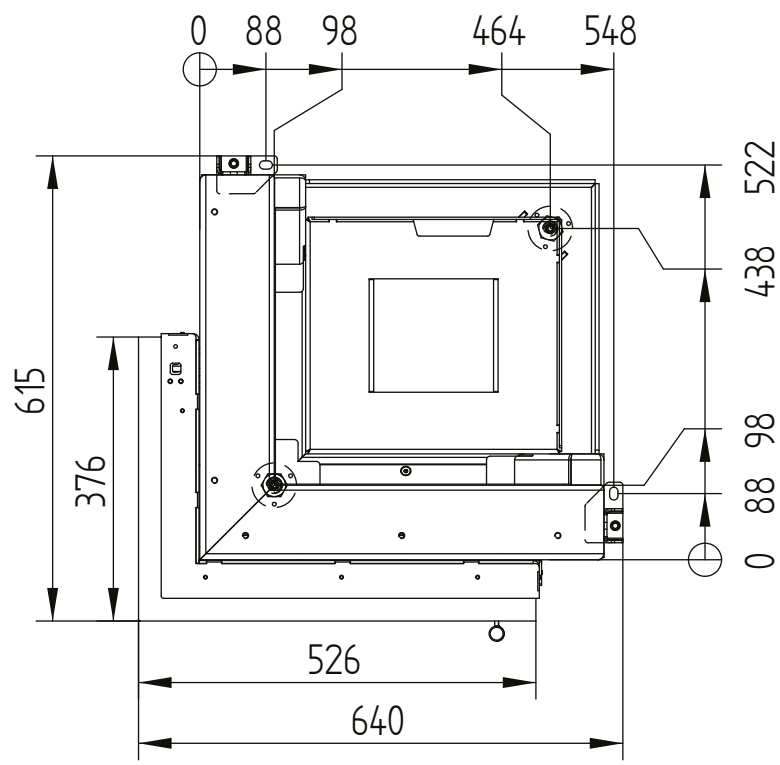
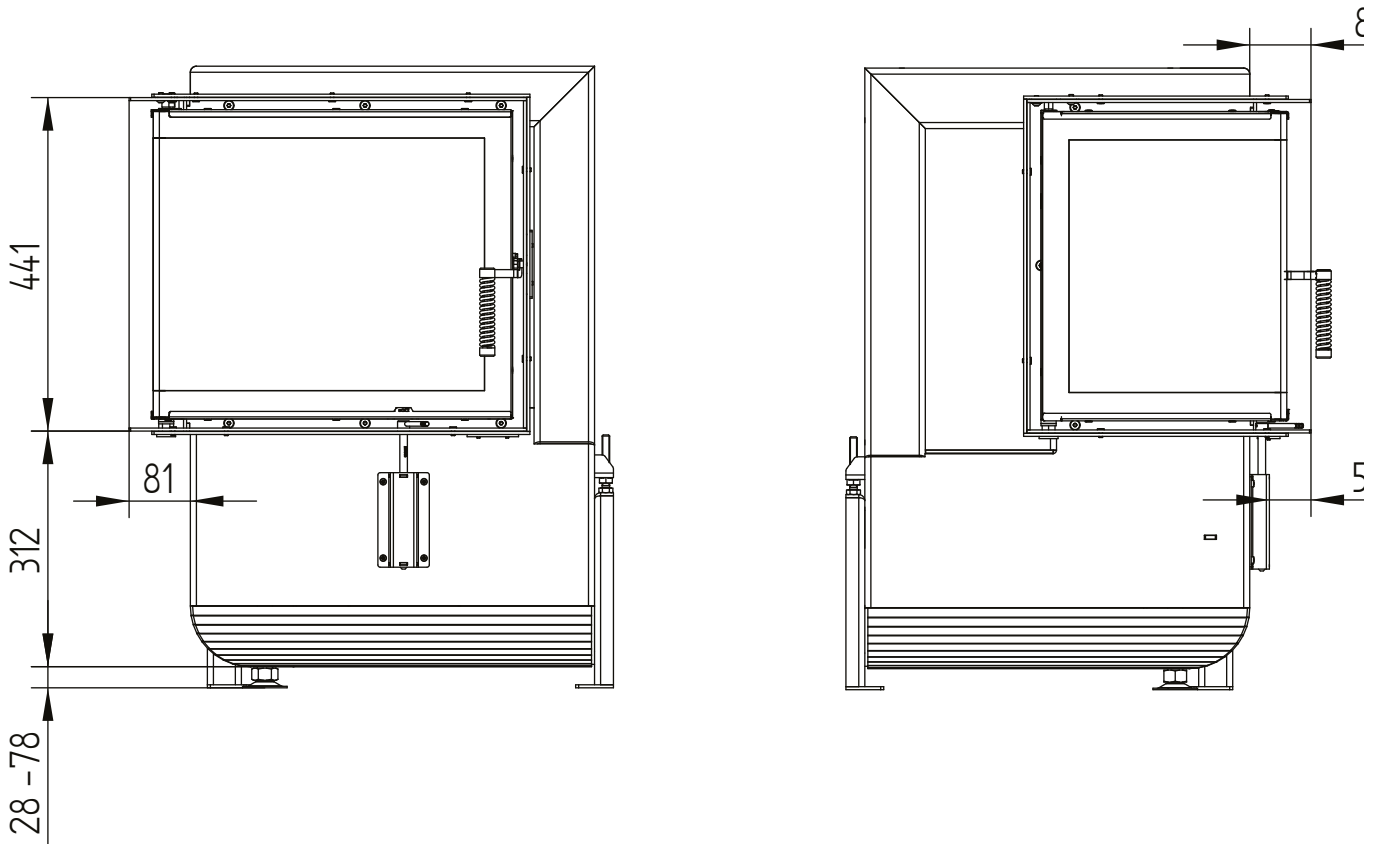

GT2 50/35/45R right

Technical data
Version 2019/08

General technical information	
Recommended wood load	10 kg
Maximum cross-section of the supply air connection	180 cm ²
Combustion air connection	1 × Ø 150 mm
Free glass area	2 555 cm ²

Load of wood	Air flow		Pressure drop
3 kg	28,2 m ³ /h	0,008 m ³ /h	0,8 Pa
4 kg	37,6 m ³ /h	0,010 m ³ /h	1,2 Pa
5 kg	47,0 m ³ /h	0,013 m ³ /s	1,8 Pa
6 kg	56,3 m ³ /h	0,016 m ³ /s	2,6 Pa
7 kg	65,7 m ³ /h	0,018 m ³ /s	3,6 Pa
8 kg	75,1 m ³ /h	0,021 m ³ /s	4,7 Pa
9 kg	84,5 m ³ /h	0,023 m ³ /s	6,0 Pa
10 kg	93,9 m ³ /h	0,026 m ³ /s	7,4 Pa
11 kg	103,3 m ³ /h	0,029 m ³ /s	9,0 Pa
12 kg	112,7 m ³ /h	0,031 m ³ /s	10,8 Pa
15 kg	140,9 m ³ /h	0,039 m ³ /s	17,1 Pa
20 kg	187,8 m ³ /h	0,052 m ³ /s	30,8 Pa

GT2 50/35/45R right

Technical data
Version 2019/08

air connection

M 1:10

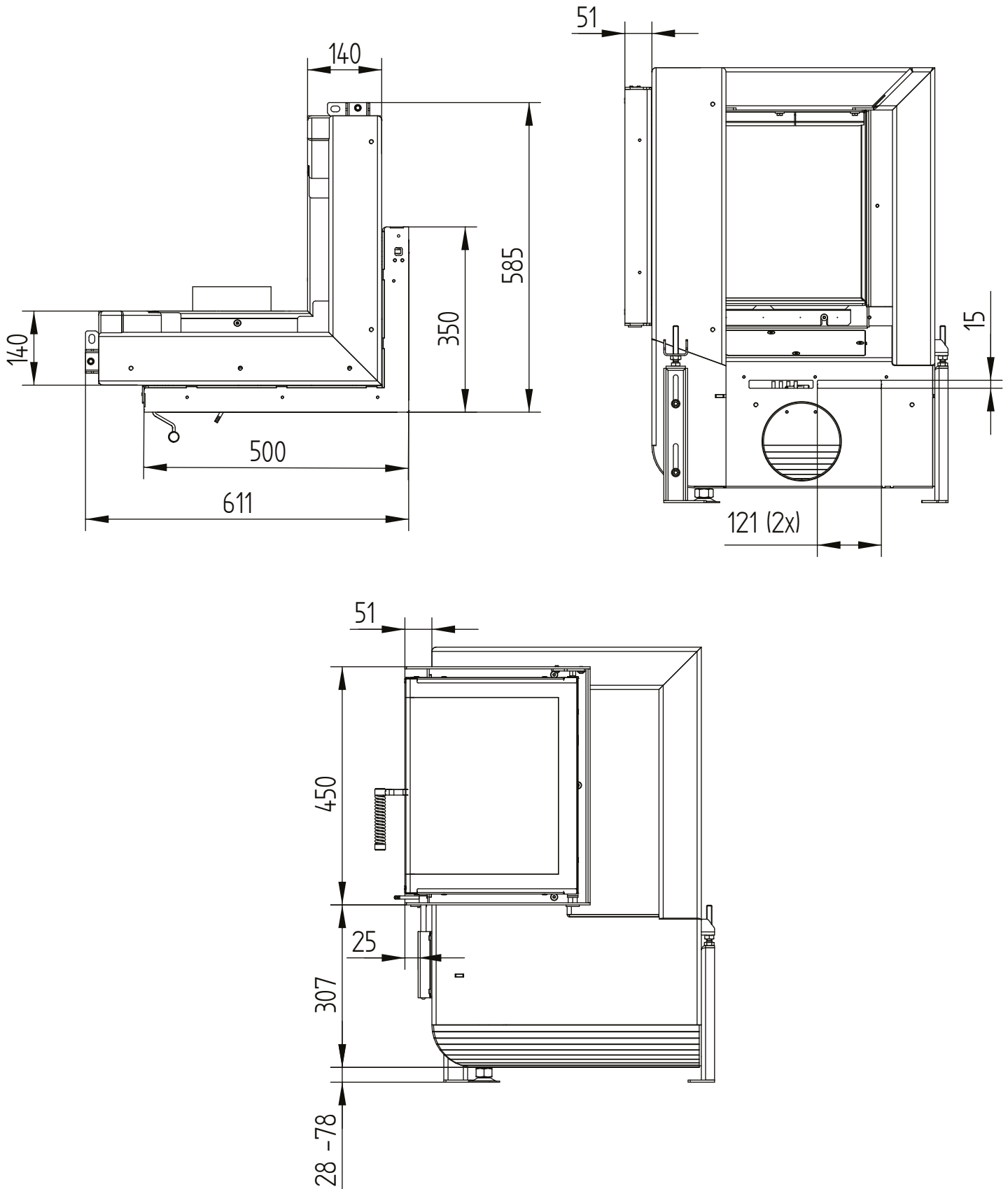

GT2 50/35/45R right

Technical data
Version 2019/08

with base

M 1:10

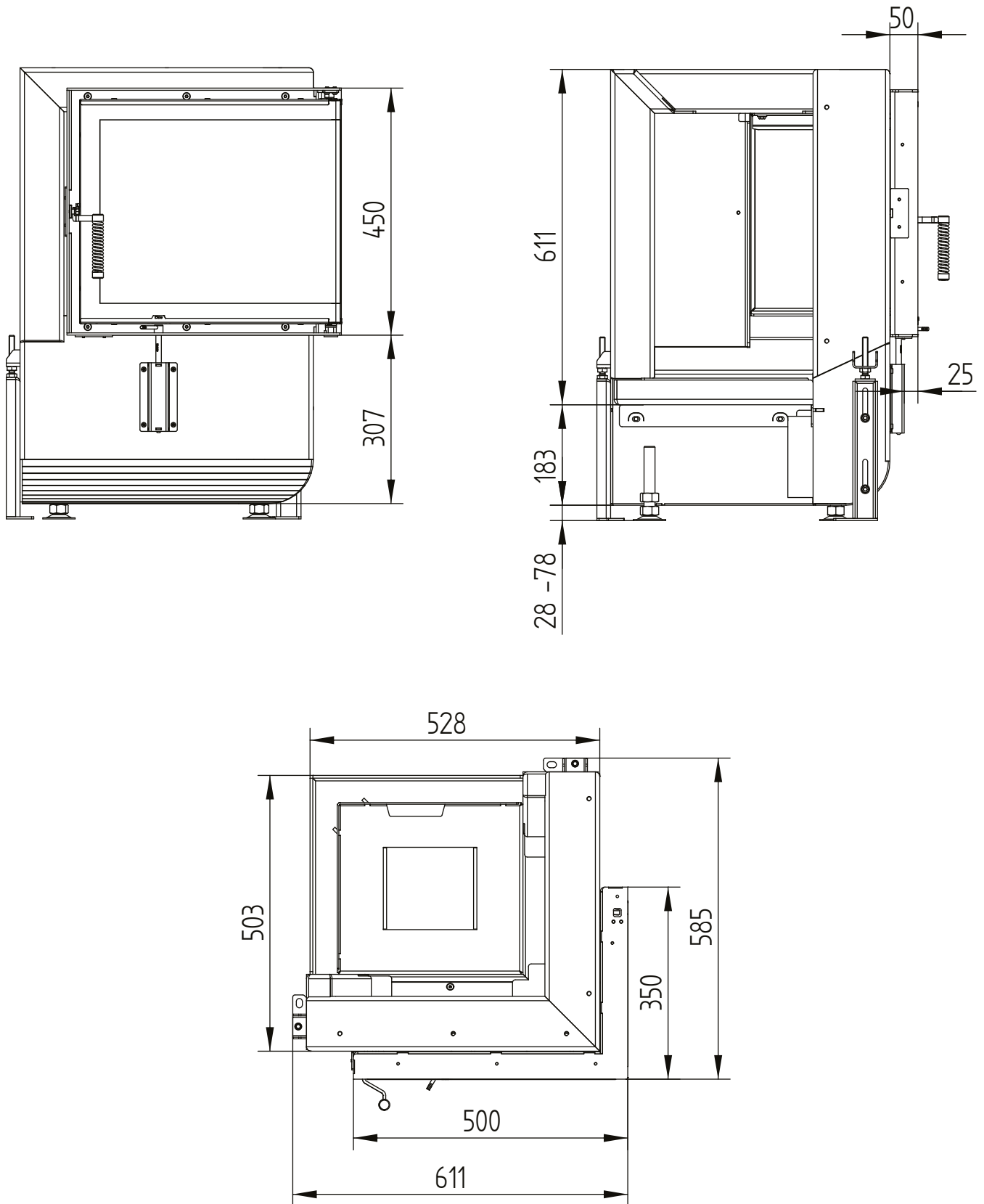

GT2 50/35/45R right

Technical data
Version 2019/08

cover frame 50/35/45R right 6sides 1 x 90° 60 mm

M 1:10

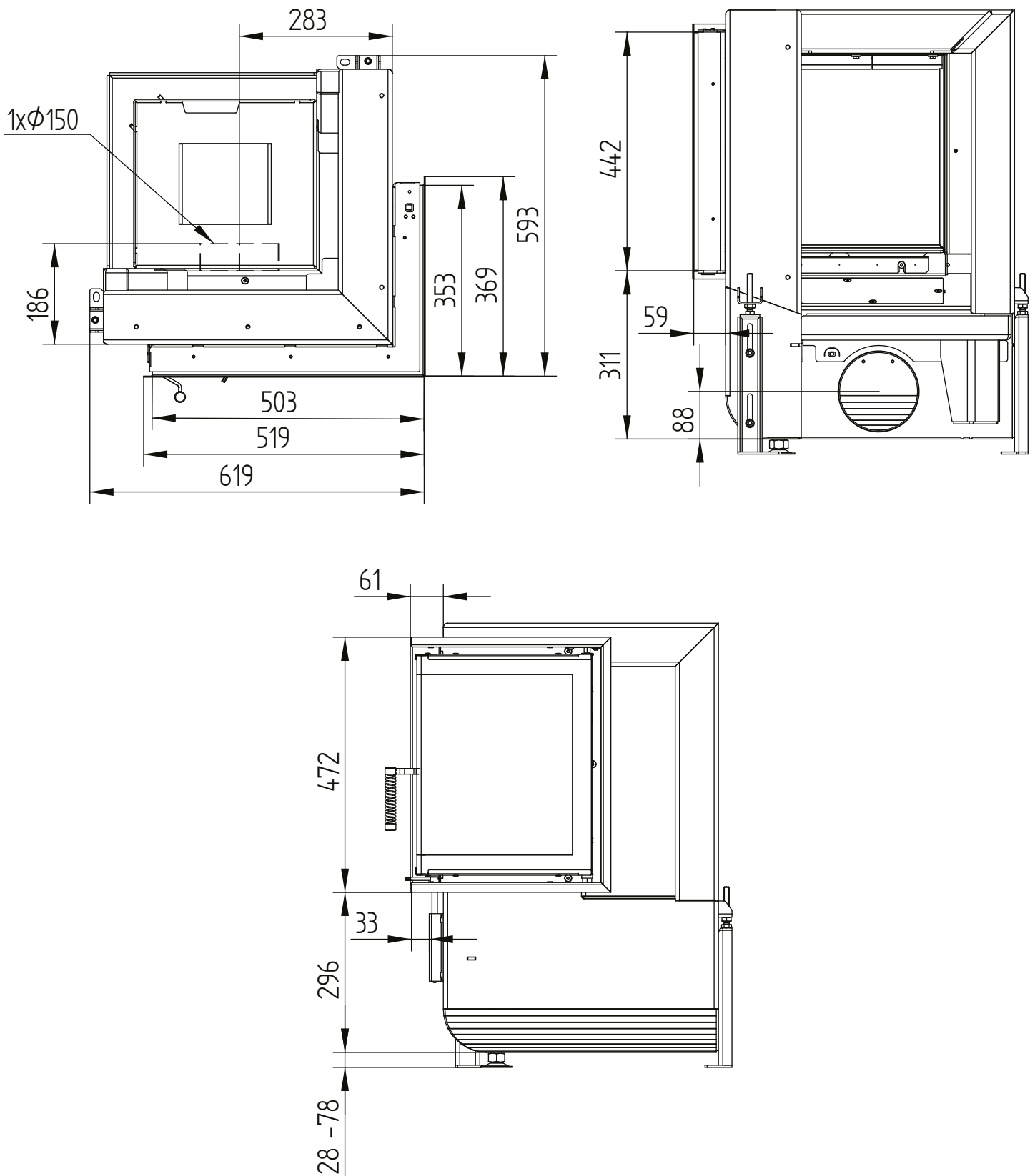

GT2 50/35/45R right

Technical data
Version 2019/08

build-on frame 50/35/45R right 6sides 80 mm / feet

M 1:10

